

直流无刷电动滚筒 BLDG: Brushless DC Drum Motor

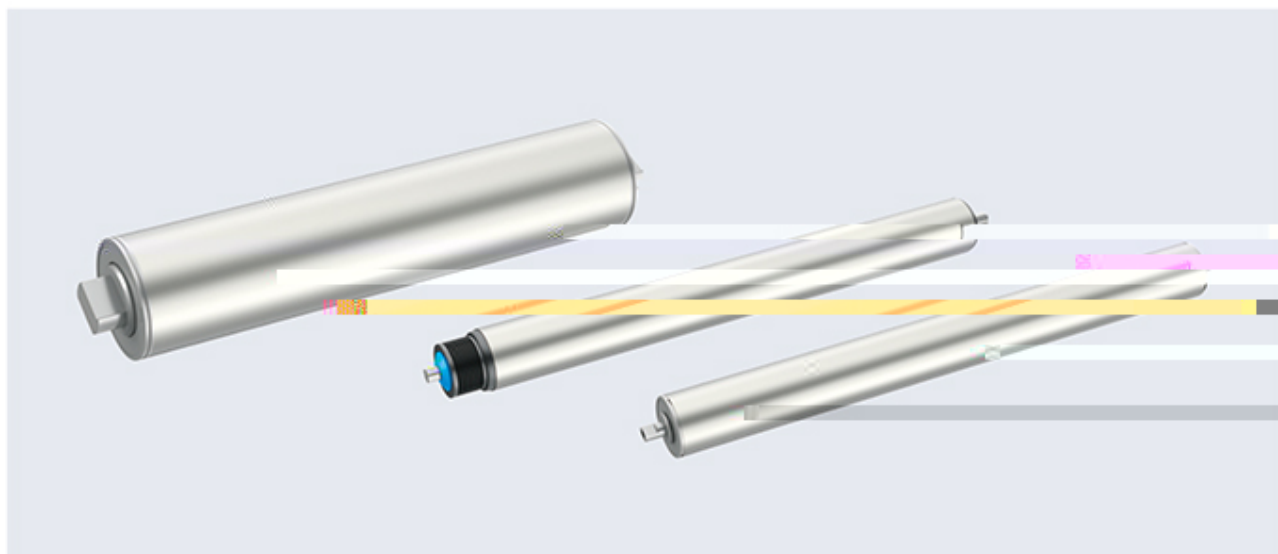

产品型号说明 Ordering Code

BLDG
82
100
24V
380
12
T
DX
Y

(1) (2) (3) (4) (5) (6) (7) (8) (9) (10)

(1) 产品代号 Product code	BLDG: 直流无刷 BLDG: DC brushless
(2) 筒体代号 Drum code	以滚筒筒体直径表示, 如 50, 60, 82 等 The diameter of drum body is indicated, such as 50, 60, 82, etc.
(3) 电机功率 Rated power	电动机的额定功率, 如 30W~150W, 型号中省略单位 W, 使用数字表示。如 150W 用 150 表示 The rated power of the motor, such as 30W~150W, is omitted in model code, and the digital representation is used. For example, 150W with 150
(4) 电压 (直流无刷) Voltage (DC brushless)	BLDG 直流无刷: DCV12 用 12V 表示; DCV24 用 24V 表示; DCV48 用 48V 表示; V 表示非标电压 (当出现 V 时表示非标电压) BLDG DC brushless: DCV12 is represented by 12V; DCV24 is represented by 24V; DCV48 is represented by 48V; V represents non-standard voltage (voltage must be indicated when V is present)
(5) 筒体长度 Drum length	按筒体的实际长度进行编号, 单位 mm 省略, 如 350mm 用 350 表示 The actual length of the drum body is used for coding, the unit mm is omitted, such as 350mm with 350
(6) 线速度 Linear speed	按实际线速度直接进行编号, 单位 m/min 省略, 如 12m/min 用 12 表示 According to the actual linear velocity, the number of unit m/min is omitted. For example, 12m/min with 12
(7) 筒体型式 Drum shape	A: 圆柱形筒体 (默认不标), B: 鼓形筒体 A: cylindrical drum body (Default no marked), B: drum drum body
(8) 筒体材料 Drum material	默认 T 为碳钢, 可不标, 其它: B3: 不锈钢 304, X: 表面镀锌, G: 表面镀硬铬, J: 包耐磨橡胶 The default T is carbon steel, not marked, other: B3: stainless steel 304, X: surface galvanizing, G: surface hard chromium, J: package wear resistant rubber
(9) 驱动连接方式 Drive connection mode	皮带型不标, DX: 多楔带型, SL: 双链轮, DL: 单链轮, GC: 滚槽型 Belt type not marked, DX: multi-wedge belt type, SL: double chain wheel, DL: single chain wheel, GC: grooved type
(10) 驱动安装方式	Y: 弹簧压入式, N: 内螺纹式 Y: Spring press-in type, N: Internal thread type

举例: BLDG82-100-24V-380-12-X

电动滚筒电机

Drum Motor

一般技术信息——直流无刷电动滚筒 General Technical Information——DC Brushless Drum Motor

■可进行稳定的速度控制 Stable Speed Control

无刷电动机持续对设定速度和来自电动机的反馈信号进行比较，来调节施加到电动机上的电压；因此，即使负载状况发生变化，仍可以从低速瞬间调整到设定速度，并以此稳定的速度运行。使用变频器控制的三相感应电动机不进行反馈控制，因此负载变大时，速度会大幅下降；对于速度稳定性要求较高的用途，建议使用无刷电动机。

Brushless motor continues to set speed and a feedback signal are compared from the speed of the motor to adjust the voltage applied to the motor; therefore, even if the load changes, it can be adjusted from slow instantaneously to the set speed and run at a stable speed. Three phase induction motor with inverter control is not feedback control, so the load becomes larger, the speed will be greatly reduced; for the high speed stability requirements, it is recommended to use brushless motor.

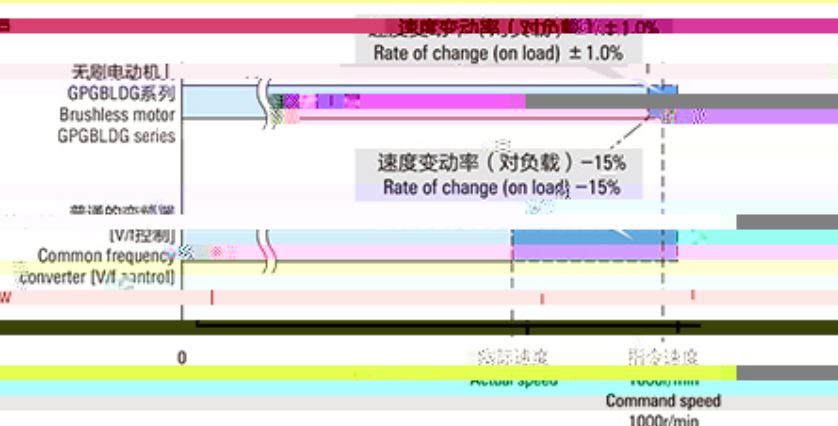

■有助于节能 Contribution to energy saving

无刷电动机的转子使用永久磁铁，可减少转子的铜损耗，因此与采用变频控制的三相感应电动机相比，耗电量减少20%以上，有助于装置节能。

The rotor of the brushless motor is made of permanent magnet, which can reduce the copper loss of the rotor, so the power consumption is reduced by more than 20% compared with the three phase induction motor with variable frequency control, which is helpful for the energy saving of the device.

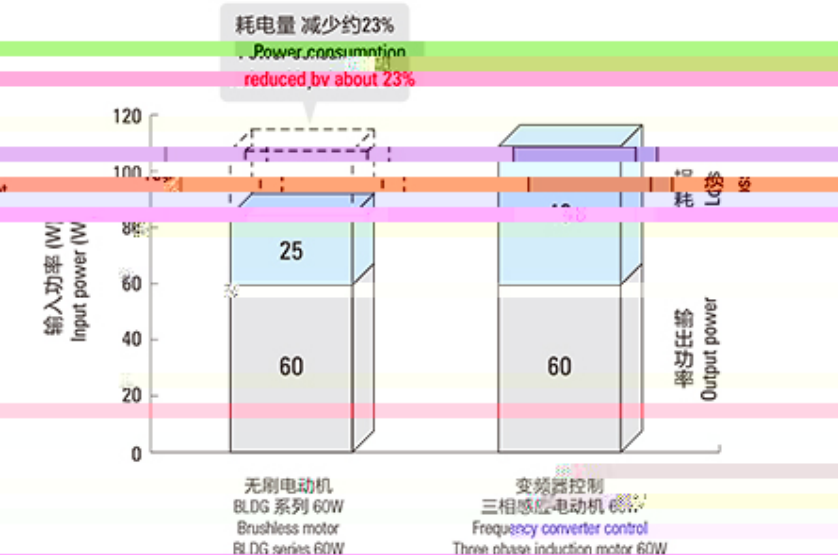

■高扭矩 High Torque

同尺寸的直流无刷电机相对于交流电机拥有更强大的扭矩，这使它能够输送更重的货物或者减少电动滚筒的数量。

A brushless DC motor of the same size has more torque than an ac motor, and it can transport heavier goods or reduce the number of electric drum rollers.

■动态刹车 Dynamic Brake

直流无刷电机提供电子刹车模式称为动态刹车，这个特点使得电动滚筒在没有使用机械刹车情况下拥有快速停止的功能（不包括货物和滚筒表面之间的打滑）。

The brushless DC motor provides an electronic braking mode known as dynamic braking, which allows the electric drum to stop quickly without the use of mechanical brakes (excluding slippage between the cargo and the surface of the drum).

一般技术信息——直流无刷电动滚筒 General Technical Information——Brushless DC Drum Motor

■ 基本信息 Basic Information

- 筒体材料: 碳钢 + 镀锌 / 不锈钢
- 最短滚筒长度: 请参考机械参数表格
- 最长滚筒长度: 1000mm (超过 1000mm 时, 请联系我们)
- 电缆标准长度: 600mm, 如有需要, 可以提供延长电缆
- Barrel material: carbon steel + galvanized/stainless steel
- Minimum drum length: please refer to the mechanical parameter table
- Longest drum length: 1000mm (for more than 1000mm, please contact us)
- Cable standard length: 600mm, extension cable can be provided if necessary

■ 直流无刷电动滚筒的三种规格——产品种类 Brushless DC Drum Motor Spec-Product Type

电动滚筒 Drum Motor	滚筒直径 Roller Diameter	输出线径 Output Wire	电机型号 Motor Model	电源电压 Voltage Supply
	50	40/60	标准型 Standard type IP40 或 Or IP65 (特殊处理) (Special treatment)	直流 24-96V DC 24-96V
	60	90		
	67	400(直驱)		
	76	120		
	82	100/200		

■ 承载重量 / 根 Bearing Weight/Root

单位: kg

直径 (mm)	长度 (mm)							
	300	400	500	600	700	800	900	1000
Φ50	80	70	60	55	50	45	40	35
Φ60	115	115	95	95	75	75	65	65
Φ76	-	190	160	160	125	125	95	95
Φ82	-	150	120	120	90	90	75	75

■ 管壁厚度 Tube Wall Thickness

直径 Diameter (mm)	Φ50	Φ60	Φ76	Φ82
厚度 Thickness (mm)	1.5	1.5	3	2.25

■ 引出线说明 Lead-out Wire Description

带霍尔引出线说明 Description with hall lead-out wire

黄 (粗) Yellow (thick)	绿 (粗) Green (thick)	蓝 (粗) Blue (thick)	黄 (细) Yellow (thin)	绿 (细) Green (thin)	蓝 (细) Blue (thin)	红 (细) Red (thin)	黑 (细) Black (thin)
U	V	W	Hu	Hv	Hw	Vcc+5V	GND